

RUMSON ROAD
NOT TO SCALE

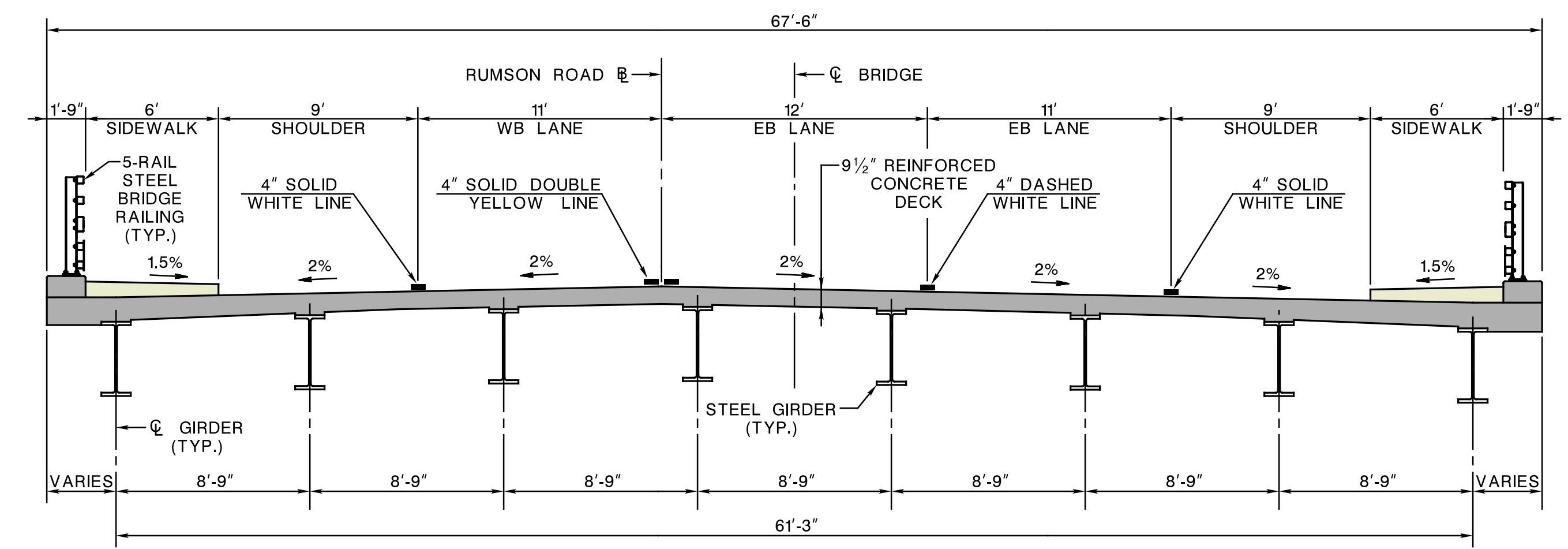

RUMSON ROAD (BRIDGE S-32)
NOT TO SCALE

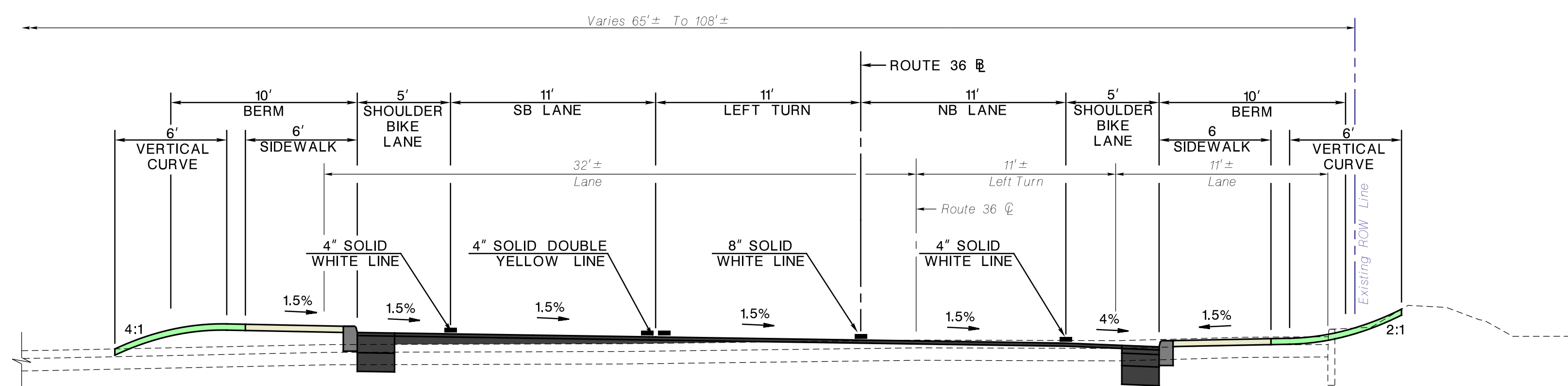

ROUTE 36
NOT TO SCALE

TYPICAL SECTIONS



LEGEND	
	- PROPOSED PAVEMENT
	- PROPOSED BRIDGE / MOVABLE
	- PROPOSED RETAINING WALL
	- PROPOSED PARKING PAVEMENT
	- PROPOSED DRIVEWAY
	- PROPOSED SIDEWALK
	- CONCRETE
	- WATER BODIES
	- LANDSCAPING
	- PROPOSED RIGHT-OF-WAY
	- EXISTING RIGHT-OF-WAY / PROPERTY

OCTOBER, 2021



REPLACEMENT OF BRIDGE S-32 ON C.R. 520 (RUMSON ROAD) over THE SHREWSBURY RIVER